

Bottom view

$\phi 2.05$

Tape 0.4mm

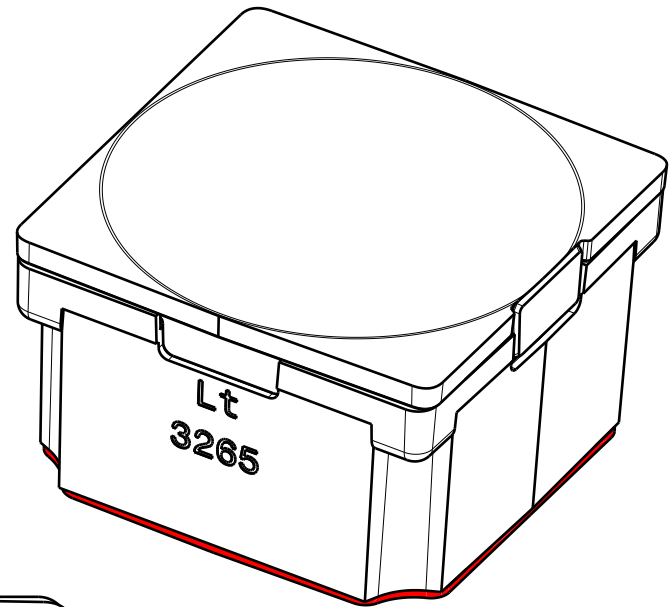

Isometric view
Scale: 3:1

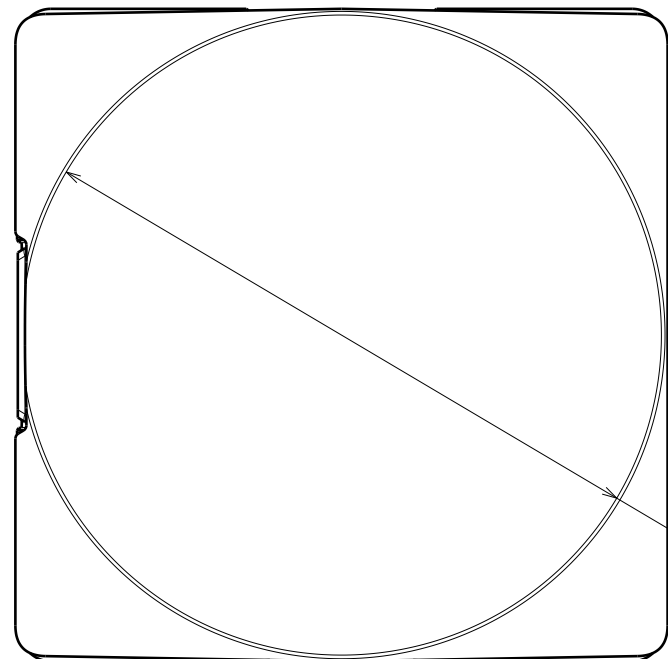

Top view

$\phi 21.16$

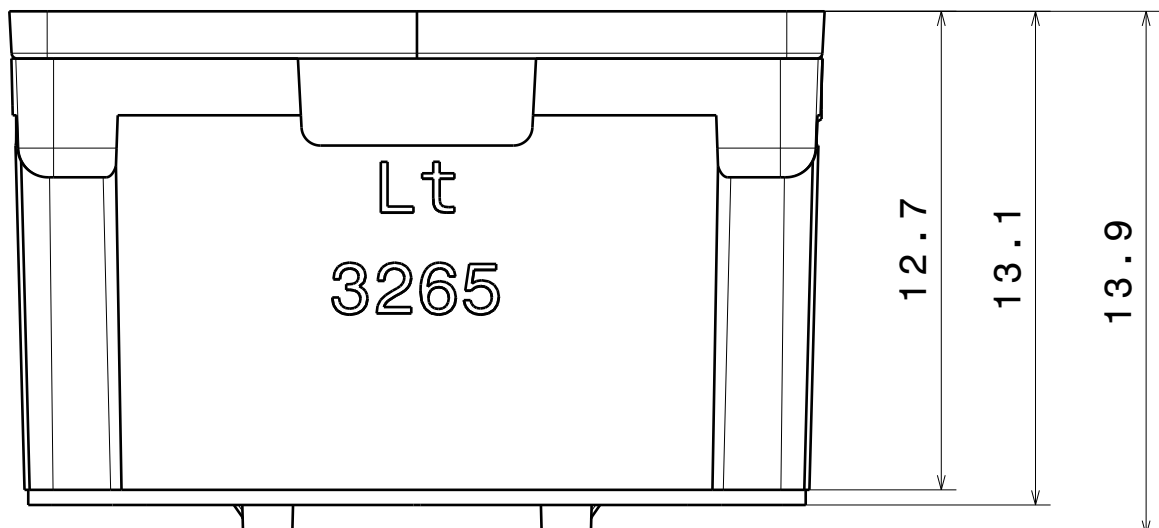

Front view

PART	TYPE	MATERIAL	COLOR / COATING
CA13627_G2-LAURA-M-P			white

MECHANICAL DRAWING		LEDiL [®]
PRODUCT	LAURA	
Plastic molding general tolerances are based on DIN 16901-130 and applies if not otherwise shown in drawing. Silicone molding general tolerances are based on ISO 3302-1 Class M3 and applies if not otherwise shown in the drawing.	FIRST ANGLE PROJECTION: 	This drawing is the property of LEDiL Oy. It may not be reproduced, copied or communicated without a written agreement with LEDiL Oy.
SCALE	4:1	WEIGHT -
		A3 SHEET 1/1